

SIMULATION OF DC MOTORS FED FROM PHOTOVOLTAIC ARRAYS

Ibrahim A.M. Abdel-Halim Hamed G. Hamed Mohammed E. Elfaraskoury

Faculty of Engineering, Benha University
Electrical Engineering Department
108 Shoubra St., Cairo, EGYPT

Abstract

In this paper the steady-state performance of different types of DC motors (series, separately-excited and shunt) fed from a photovoltaic array are obtained by the simulation of the photovoltaic array / motor system using MATLAB/SIMULINK environment.

To validate the simulations presented in this paper, the results obtained from the simulations of the system were compared with results obtained using MATLAB as a programming tool and the two sets of results were identical.

Keywords: Photovoltaic arrays; Simulation; DC motors.

1. Introduction

Photovoltaic (PV) arrays, which convert solar energy into electrical energy, are considered as one of the clean renewable energy sources. Several investigations have been conducted on applications in which PV arrays are used [1-5]. Among the applications in which PV arrays are used is water pumping in which a DC motor or a permanent magnet (PM) motor driving a water pump, for drinking or irrigation, is fed from a PV array [1,3,4,6].

The performance characteristics of DC motors fed from PV arrays have been investigated before [6,7], and that of the PM motor was also investigated [3]. The performance characteristics were, usually, obtained using high-level programming languages. In this paper, therefore, the MATLAB/SIMULINK package [8], which has been used extensively in several investigations, regarding machines and drives, as a simulation tool [2,9,10,11], has been used to develop a simulation for the PV array fed series, separately-excited (SE) and shunt DC motors. The approach presented in this paper is much simpler than other approaches used to analyze systems in

which photovoltaic arrays and DC motors are used [2,3,6,7,12]. The method presented is direct, and computation time required is much less than other numerical methods used.

2. Method of Simulation

The PV array consists of several modules connected in series-parallel combination, depending on the required voltage and current to feed certain load. The PV array has an I-U characteristic given by [6]:

$$U_g = (1/\Lambda_g) \ln[(G I_{phg} + I_{og} - I_g)/I_{og}] - I_g R_{sg} \quad (1)$$

where:

U_g is the output voltage of the array, $\Lambda_g = \Lambda_m / N_s$, N_s is the number of series connected modules in one string, $\Lambda_m = \Lambda / N_{sm} = q / N_{sm} m k T$, N_{sm} is the number of cells connected in series, $\Lambda = q / mkT$ is a cell factor that depends on its temperature [13], q is the electron charge (1.602×10^{-19} C), m is an empirical nonidealty factor whose value is usually close to unity, k is the Boltzmann constant (1.38×10^{-23} J/K), T is the absolute cell temperature, G is the insolation level to which the PV array is subjected, $I_{phg} = I_{ph} N_p$, I_{ph} is the cell photocurrent at standard test conditions (STC) [13], N_p is the number of parallel strings,

$I_{og} = I_o N_p$, I_o is the cell reverse saturation current [13], $I_g = I N_p$, I is the current per string of modules which are connected in series, $R_{sg} = R_{sm} N_s / N_p$, R_{sm} is the resistance of the module and is related to the resistance of one cell (R_s) by: $R_{sm} = N_{sm} R_s$

(2.1) Simulation of the PV Array/Series DC Motor System

The steady-state voltage equation of the series motor is:

$$U = I_a (R_a + R_f) + M_{af} I_a \omega \quad (2)$$

where:

U and I_a are the motor terminal voltage and armature current where they are equal to U_g and I_g respectively when the motor is fed from a PV-array, R_a , R_f are the armature and field winding resistances, M_{af} is the mutual inductance between the armature and field windings of the motor.

Thus, from eqns.(1) and (2) we get:

$$U_g = I_g (R_a + R_f) + M_{af} I_g \omega$$

Therefore, the speed equation will be:

$$\omega = (1/M_{af} I_g \Lambda_g) \ln[(G I_{phg} + I_{og} - I_g)/I_{og}] - (R_a + R_f + R_{sg})/M_{af} \quad (3)$$

The developed torque of the series DC motor will, therefore, be:

$$T_e = M_{af} I_g^2 \quad (4)$$

For a certain required torque, the motor armature current, or the PV array current, is:

$$I_g = \sqrt{T_e / M_{af}} \quad (5)$$

From eqn. (5) into eqn. (3) we get the speed-torque characteristics of the motor when fed from a PV array as:

$$\omega = - [(R_{sg}+R_a+R_f)/ M_{af}] + [1/ (M_{af} \Lambda_g \sqrt{T_e / M_{af}})] \ln [1+ [(G I_{phg} - \sqrt{T_e / M_{af}})/I_{og}]] \quad (6)$$

Eqn. (6) is simulated using SIMULINK as shown in the block diagram of Fig. (1) in which the input to the system is the required developed torque of the motor (T_e) and the output is the motor speed (ω_r) for certain insolation level (G).

Eqn. (5) is included in the simulation of Fig. (1) to obtain the motor current ($I_a=I_g$) which is the PV array current corresponding to any value of the motor torque. From this simulation the terminal voltage of the PV array (U_g), which is applied to the motor, can be also obtained.

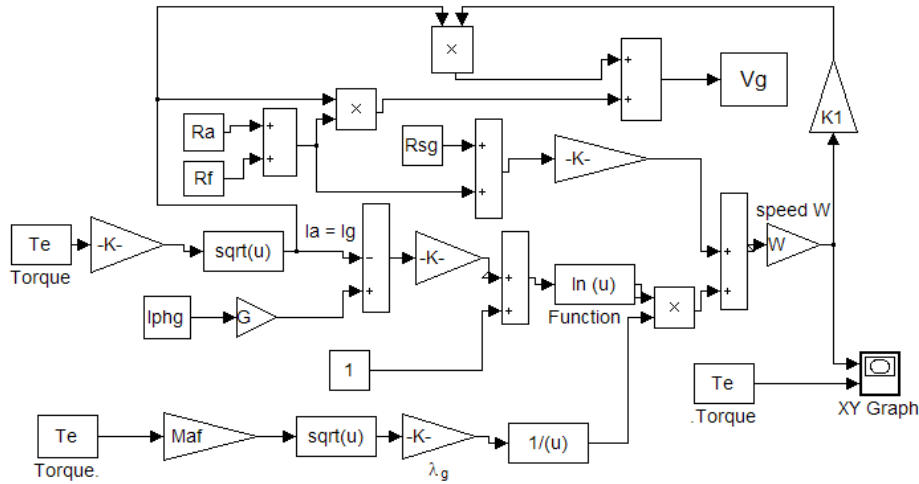

Fig. (1) Block diagram for the simulation of the PV array/series DC motor system.

(2.2) Simulation of the PV Array/ Separately-Excited DC Motor System

The voltage equation of the SE DC motor is:

$$U_g = I_g R_a + K_2 \omega \quad (7)$$

where K_2 is the machine constant and is assumed to be constant since the field current will be assumed constant at its rated value. The electromagnetic torque developed by the motor is given by:

$$T_e = K_2 I_g \quad (8)$$

Thus, from eqns.(1) and (7) we get:

$$\omega = (1/K_2 \Lambda_g) \ln [(G I_{phg} + I_{og} - I_g)/I_{og}] - I_g (R_a + R_{sg})/K_2 \quad (9)$$

Combining eqns.(8) and (9), speed-torque characteristics of the motor is obtained as:

$$\omega = - [T_e (R_{sg} + R_a)/ K_2^2] + [1/ (\Lambda_g K_2)] \ln [1+ [(G I_{phg} - T_e / K_2)/I_{og}]] \quad (10)$$

Eqn. (10) is simulated using SIMULINK and the corresponding block diagram is shown in Fig. (2). In this figure the required developed torque of the motor (T_e) is the input to the system and the speed (ω_r) is its output. The current (I_g) and voltage (U_g) of the armature are included in the simulation.

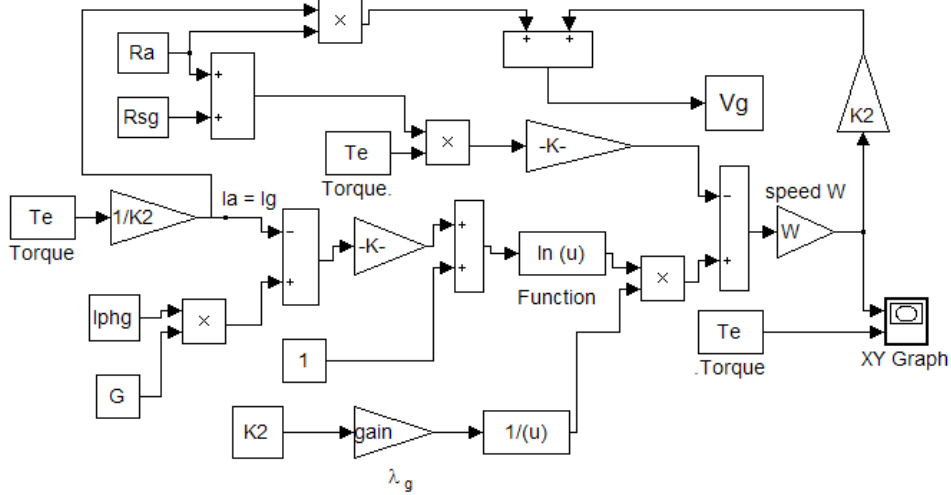

Fig. (2) Block diagram for the simulation of the PV array/SE DC motor system.

(2.3) Simulation of the PV Array/Shunt DC Motor System

The steady-state armature current and voltage equation of the shunt motor is:

$$U = I_a R_a + M_{af} I_f \omega \tag{11}$$

and the corresponding equation for the field is:

$$U = I_f R_f \tag{12}$$

The motor line current, I , is given by:

$$I = I_a + I_f \tag{13}$$

and the motor torque can be found from:

$$T_e = M_{af} I_a I_f \tag{14}$$

U and I are the shunt motor terminal voltage and current where they are equal to U_g and I_g respectively when the motor is fed from a PV-array, I_a , I_f are the armature and field winding currents, R_a , R_f are the armature and field winding resistances, M_{af} is the mutual inductance between the armature and field windings of the motor. When the shunt motor is fed from the PV array, an expression relating the motor developed torque with its speed can be derived as:

$$\sqrt{T_e R_a R_f^2 / M_{af} (R_f - M_{af} \omega)} = - [(R_a + R_f - M_{af} \omega) \sqrt{R_{sg}^2 T_e / [R_a M_{af} (R_f - M_{af} \omega)]} + (1/\Lambda_g) \ln [1 + [(G I_{phg} - I_y)/I_{og}]]] \tag{15}$$

However, for any given value of the developed torque by the motor, in order to obtain the corresponding speed from eqn. (15) we need to solve this equation numerically because it is a transcendental equation. Therefore, to obtain the shunt motor performance characteristics without solving a transcendental equation numerically, the following approach is used:

(a) For certain motor line current (I), i.e. for certain PV array current (I_g), the corresponding array voltage (U_g) is computed from eqn. (1).

(b) Since the PV array voltage is the applied voltage to the shunt motor then the field current is computed using eqn. (12) as:

$$I_f = U_g / R_f$$

(c) Using eqn. (13) the armature current, I_a , is obtained from:

$$I_a = I - I_f$$

(d) From eqn. (14) the developed motor torque is obtained.

(e) The corresponding motor speed is obtained using eqn. (11) as:

$$\omega = (U_g - I_a R_a) / M_{af} I_f \quad (16)$$

This approach is simulated using SIMULINK as shown in the block diagram of Fig. (3).

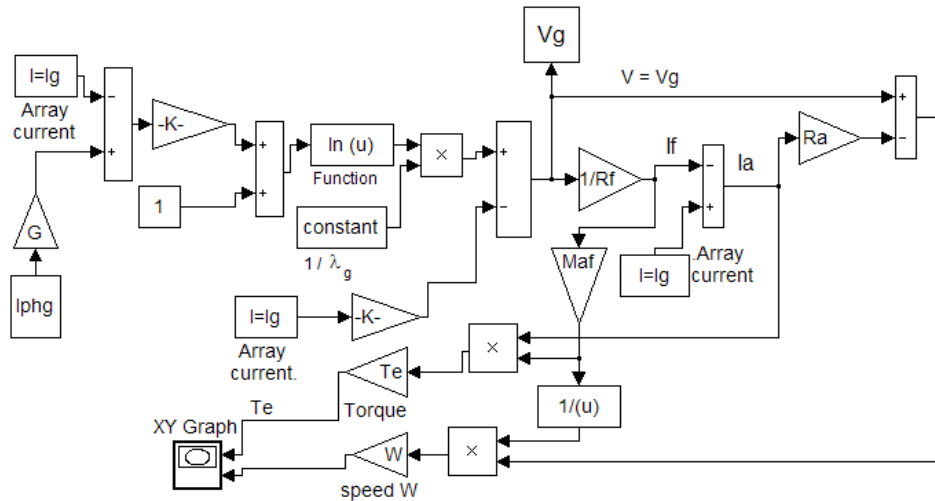

Fig. (3) Block diagram for the simulation of the PV array/shunt DC motor system.

3. Results

The simulations presented in Figs.(1) to (3), using SIMULINK, for the series, the separately-excited and the shunt DC motors, respectively, when fed from a PV array were used to obtain the speed-torque characteristics for the motors. The parameters of the DC motors used and of the PV module used in the array are given in the Appendix [12, 14]. Fig. (4) shows the results for the series motor,

Fig. (5) shows the results for the separately-excited motor and Fig. (6) shows the results for the shunt motor. For all cases three values of insolation levels were used which are $G=1.0$ pu, 0.8 pu and 0.6 pu.

To validate the results obtained from the presented simulations the torque-speed characteristics were obtained using normal MATLAB programming and the two sets of results are found to be identical. The performance characteristics for the series motor, Fig. (4), and for the separately excited motor, Fig. (5) show that as the load torque on the motor increases, the speed decreases for all insolation levels considered. However, to explain the behavior of the shunt motor regarding its torque-speed characteristics, Fig.(6), we refer to Fig.(7) which shows the variation of the PV array power and the developed mechanical power from the DC shunt motor versus the PV array voltage for an insolation level of $G = 1.0$ pu. . From this figure the value of the voltage at which maximum power is obtained is found to be 124 V. Also, Fig. (8) shows the variation of the PV array power and the developed mechanical power versus the motor speed for $G = 1.0$ pu. From this figure it is found that the maximum power is obtained at a speed of 1620 rpm. Applying these results to the torque-speed characteristics, Fig. (6), we find that the maximum torque which is 6.48 Nm occurs at the same speed at which the maximum power occurs which is 1620 rpm. Since the motor could not develop a mechanical power higher than the maximum power given by the PV array, as shown in Figs.(7) and (8), then with higher values of voltages and speeds the developed torque will decrease.

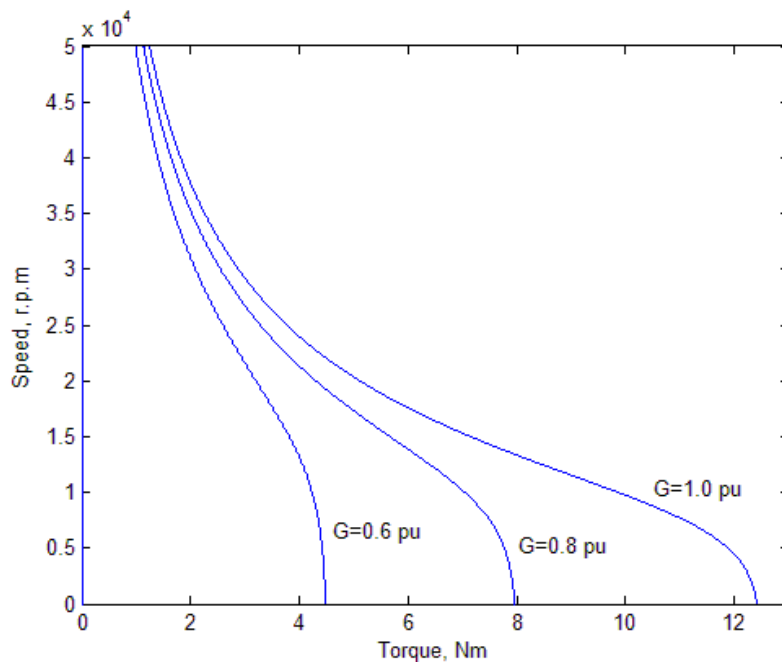

Fig. (4) speed-torque characteristics of the series DC motor (obtained from the block diagram of Fig. (1)).

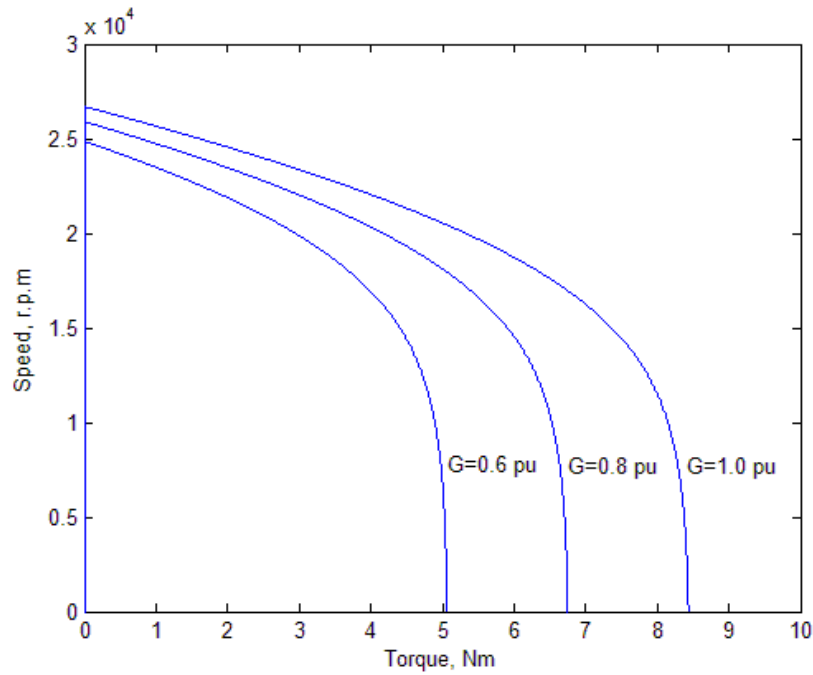

Fig. (5) speed-torque characteristics of the separately-excited DC motor (obtained from the block diagram of Fig. (2)).

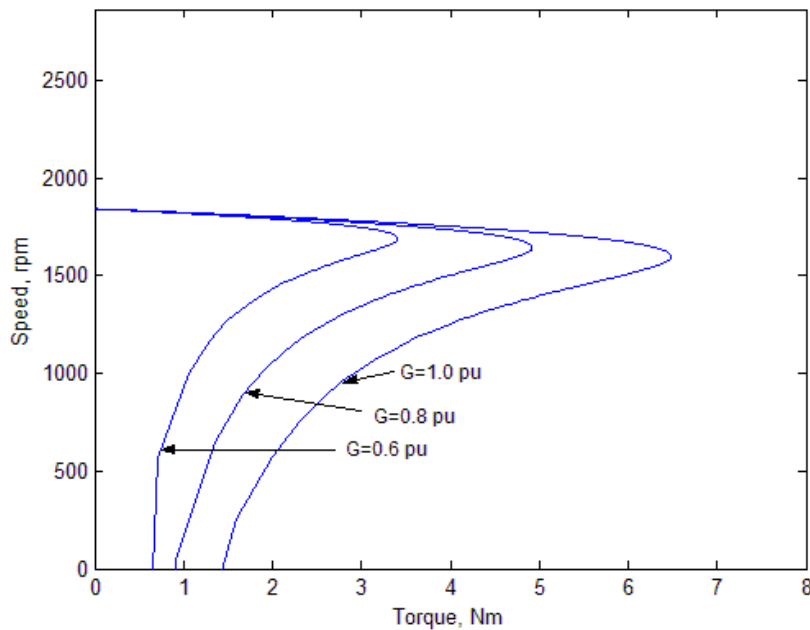

Fig. (6) speed-torque characteristics of the shunt DC motor (obtained from the block diagram of Fig. (3)).

Fig.(9) shows the variation of the DC shunt motor total current, armature current, field current and PV array voltage versus the motor speed for $G = 1.0$ pu. It is evident from this figure that as the motor speed increases the motor total current decreases, the armature current decreases and the field current increases. This situation is sustained until the no-load speed is reached at which the

armature current is approximately zero and the motor total current will be equal to the field current with the corresponding PV array voltage is the highest voltage obtained from it.

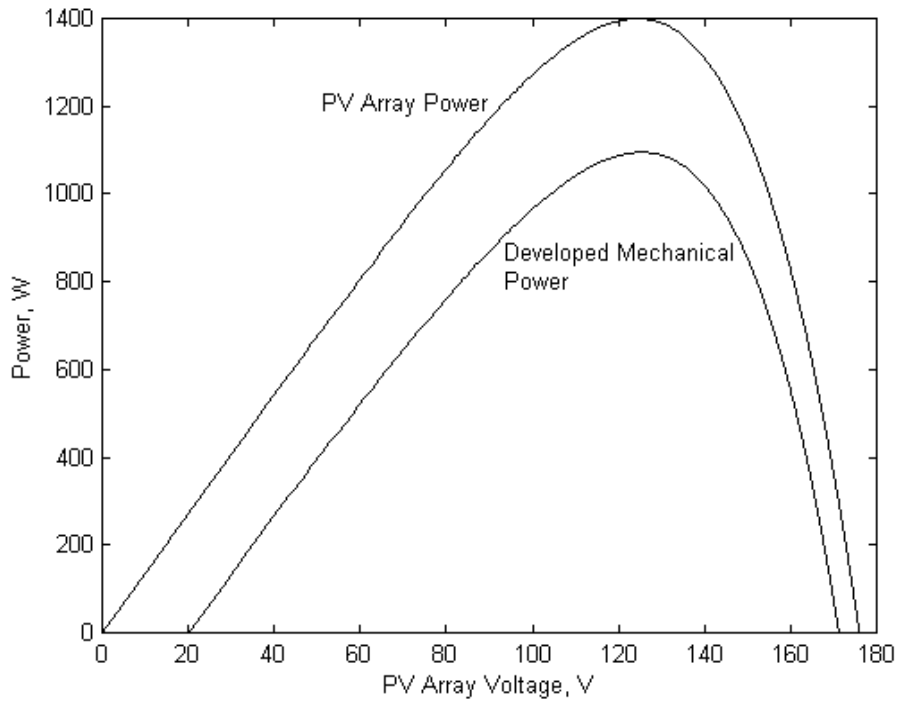

Fig. (7) PV array power and developed power versus PV array voltage characteristics of the DC shunt motor for $G = 1.0$ pu.

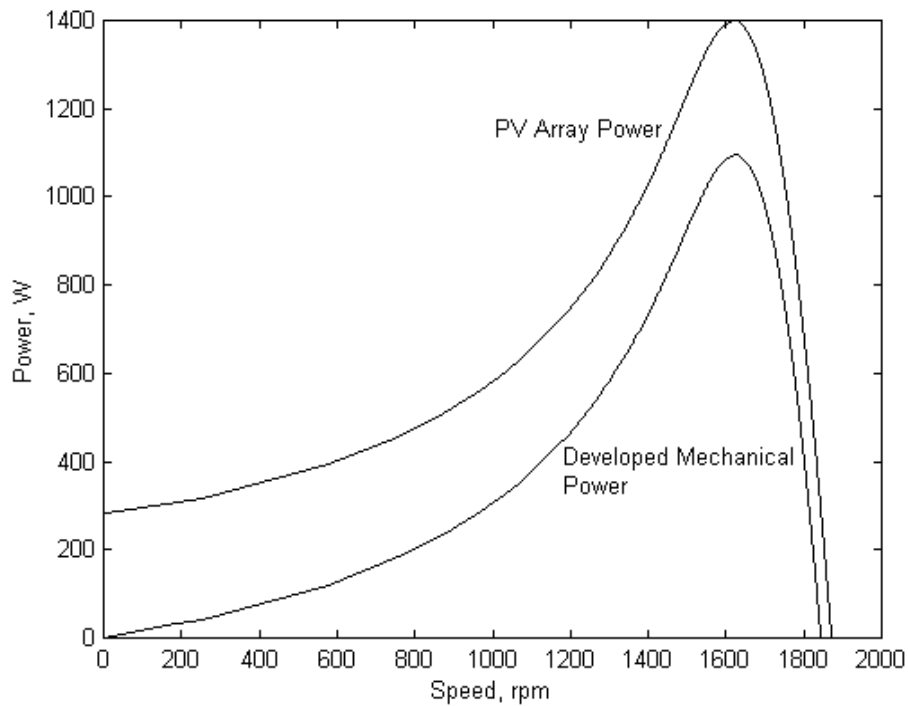

Fig. (8) PV array power and developed power versus speed characteristics of the DC shunt motor for $G = 1.0$ pu.

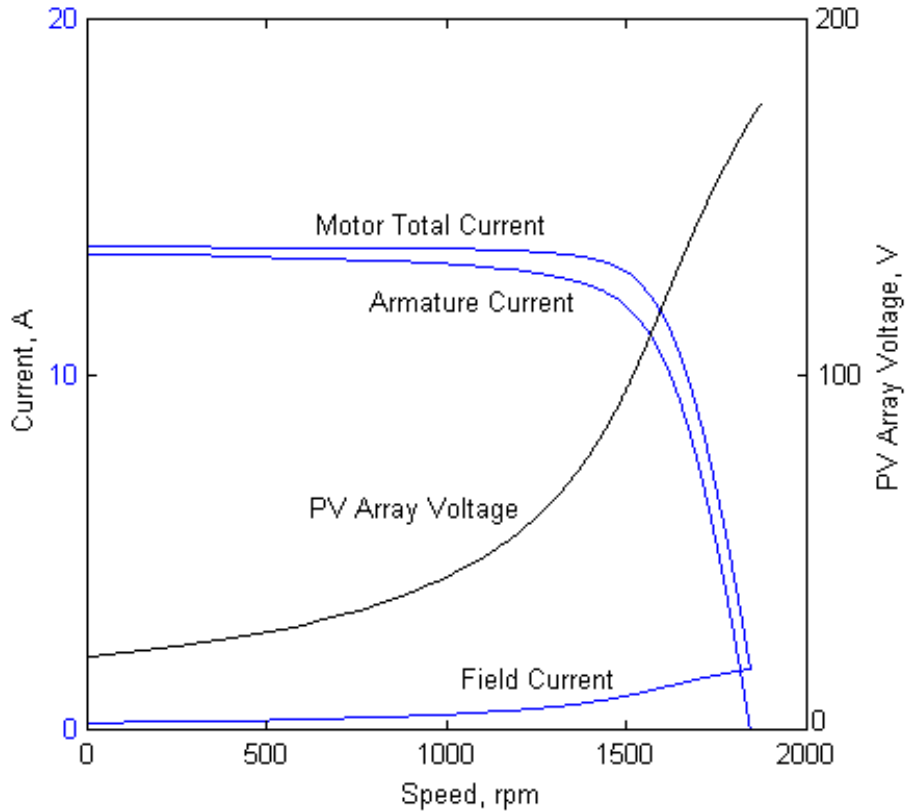

Fig. (9) Motor total current, armature current, field current and PV array voltage versus speed characteristics of the DC shunt motor for $G = 1.0$ pu.

4. Conclusions

A simple and direct method for simulating DC motors fed from PV arrays using MATLAB/SIMULINK simulation package has been presented. From these simulations, the performance characteristics of the motor and the PV array feeding them can be obtained. The results obtained from the simulations presented are identical with the results obtained from normal programming using MATLAB compared with other published methods of analysis, the method presented consumes less computation time.

5. List of Symbols

G	The insolation level in per unit.
I_a	The DC motor armature current, A.
I_f	The DC motor field current, A.
I_g	The output current of the PV array, A.
I_{MPP}	Photovoltaic cell current at maximum power point, A.
I_o	The cell reverse saturation current, A.

I_{og}	The array reverse saturation current, A.
I_{ph}	Photovoltaic cell photocurrent, A.
I_{phg}	Photovoltaic array photocurrent, A.
I_{sc}	Photovoltaic module short-circuit current, A.
$K_1 = M_{af}$	The DC series motor constant.
K_2	The DC separately-excited motor flux coefficient.
$K_3 = M_{af}$	The DC shunt motor constant.
k	Boltzman constant (1.38×10^{-23} J/K).
M_{af}	Mutual inductance between armature and field windings, H.
m	An empirical nonidealty factor whose value is usually close to unity.
N_s	The number of series connected PV modules per string.
N_{sm}	The number of series cells in a PV module.
N_p	The number of parallel connected strings in a PV array.
P_{MPP}	The maximum power produced by a photovoltaic cell, W.
q	The electron charge (1.602×10^{-19} C).
R_a	The DC motor armature winding resistance, Ω .
R_f	The DC motor field winding resistance, Ω .
R_s	The PV cell series resistance, Ω .
R_{sm}	The PV module series resistance, Ω .
R_{sg}	The PV array series resistance, Ω .
T	The absolute cell temperature, in Kelvin.
U_g	The output voltage of the PV array, V.
U_{MPP}	Photovoltaic cell voltage at maximum power point, V.
U_{oc}	Photovoltaic module open-circuit voltage, V.
Λ	Photovoltaic cell factor.
Λ_m	Photovoltaic module factor.
Λ_g	Photovoltaic array factor.
ω	The DC motor speed, mechanical rad. /s.

6. References

- [1] Miao Zhang, Jie Wu and Hui Zhao, "The application of slide technology in PV maximum power point tracking system", IEEE Intelligent control and automation, 2004. WCICA 2004. Fifth World Congress, Vol.6, pp. 5591-5594, 2004.

- [2] Patel. H. and Agarwal. V., “MATLAB-Based Modeling to Study the Effects of Partial Shading on PV Array Characteristics”, IEEE Trans. on Energy conversion, Vol.23, No.1, pp. 302-310, 2008.
- [3] Kolhe. M., Joshi, J. C. and Kothari. D.P., “ Performance analysis of a direct coupled photovoltaic water-pumping system”, IEEE Trans. on Energy Conversion, Vol.19, No.3, pp. 613-618, 2004.
- [4] M. Akbaba and M. C. Akbaba, “Dynamic Performance of a Photovoltaic-Boost Converter Powered DC Motor-Pump System”, IEEE International Conference on Electric Machines and Drives, pp. 356-361, 2001.
- [5] T. Shimizu, O. Hashimoto and G. Kimura, “A Novel High-Performance Utility-Interactive Photovoltaic Inverter System”, IEEE Trans. on Power Electronics, Vol.18, No.2, pp. 704-711, 2003.
- [6] I. A. M. Abdel-Halim, G. Hamed and M. A. Al-Ahmar, “Effect of Cell Temperature on the Performance of a Photovoltaic Generator/DC Motor System”, 6th Middle-East Power Systems Conference (MEPCON' 98), Egypt, Vol.2, pp. 706-710, 1998.
- [7] S. M. Alghuwainem, “Steady-State Performance of DC Motors Supplied From Photovoltaic Generators With Step-Up Converter”, IEEE Trans. on Energy Conversion, Vol.7, No.2, pp. 267-272, 1992.
- [8] " SIMULINK 1.3 Release Notes", the Mathworks, Inc. 1994.
- [9] A. Dumitrescu, F. David, V. Burtea, T. Jokinen and M. Rosu, “Combined Simulink-Finite Elements Approach to Inverter Driven Induction Motor”, IEEE International Conference on Electric Machines and Drives, pp. 401-403, 1999.
- [10] B. Karanayil, M. F. Rahman and C. GranthamA., “A Complete Dynamic Model for a PWM VSI-Fed Rotor Flux Oriented Vector Controlled Induction Motor Drive Using SIMULINK”, the 3rd International Conference on Power Electronics and Motion Control, Vol.1, pp. 284-288, 2000
- [11] T. Lixin and M. F. Rahman, “A New Direct Torque Control Strategy for Flux and Torque Ripple Reduction for Induction Motors Drive- A Matlab/Simulink Model”, IEEE International Conference on Electric Machines and Drives, pp. 884-890, 2001.
- [12] J. Appelbaum, “Starting and Steady-State Characteristics of DC Motors Powered by Solar Cell Generators”, IEEE Trans. on Energy Conversion, Vol.EC-1, No.1, pp. 17-25, March 1986.
- [13] Tomas Markvart (Editor), " Solar Electricity", (Book), John Wiley&Sons, 1995.
- [14] SOLAREX Solar Module MSX-77 Manufacturer Catalogue Sheet, 1999.

7. Appendix

(7.1) Parameters of SOLAREX PV Module (MSX-77/12V) Used in the Array

Maximum power rating $P_{\max} = 77 \text{ W}$

Minimum power rating $P_{\max} = 72 \text{ W}$

Rated current $I_{\text{MPP}} = 4.56 \text{ A}$

Rated voltage $U_{\text{MPP}} = 16.9 \text{ V}$

Short circuit current $I_{\text{SC}} = 5.0 \text{ A}$

Open circuit voltage $U_{\text{OC}} = 21.0 \text{ V}$

$\Lambda_m = 1.0815$

$R_{\text{sm}} = 0.5465 \Omega$

$I_o = 6.8398 \times 10^{-10} \text{ A}$

$I_{\text{ph}} = 5.0 \text{ A}$

(7.2) Parameters of the Motors

a. Series Motor:

$U = 120 \text{ V}$

$I_a = 9.2 \text{ A}$

$R_a = 1.5 \Omega$

$R_f = 0.7 \Omega$

$M_{\text{af}} = 0.0675 \text{ H}$

b. Separately-Excited Motor

$U = 120 \text{ V}$

$I_a = 9.2 \text{ A}$

$R_a = 1.5 \Omega$

$K_e = 0.621 \text{ V/rad/sec}$

c. Shunt Motor:

$U = 120 \text{ V}$

$I_a = 9.2 \text{ A}$

$R_a = 1.5 \Omega$

$R_f = 100 \Omega$

$M_{\text{af}} = 0.518 \text{ H}$

8. Figures Legend

- Fig. (1)** Block diagram for the simulation of the PV array/series DC motor system.
- Fig. (2)** Block diagram for the simulation of the PV array/SE DC motor system.
- Fig. (3)** Block diagram for the simulation of the PV array/shunt DC motor system.
- Fig. (4)** speed-torque characteristics of the series DC motor (obtained from the block diagram of Fig. (1)).
- Fig. (5)** speed-torque characteristics of the separately-excited DC motor (obtained from the block diagram of Fig. (2)).
- Fig. (6)** speed-torque characteristics of the shunt DC motor (obtained from the block diagram of Fig. (3)).
- Fig. (7)** PV array power and developed power versus PV array voltage characteristics of the DC shunt motor for $G = 1.0$ pu.
- Fig. (8)** PV array power and developed power versus speed characteristics of the DC shunt motor for $G = 1.0$ pu.
- Fig. (9)** Motor total current, armature current, field current and PV array voltage versus speed characteristics of the DC shunt motor for $G = 1.0$ pu.